

# **STEEL BUILDINGS IN EUROPE**

## **Multi-Storey Steel Buildings**

### **Part 3: Actions**



# **Multi-Storey Steel Buildings**

## **Part 3: Actions**



## FOREWORD

This publication is part three of a design guide, *Multi-Storey Steel Buildings*.

The 10 parts in the *Multi-Storey Steel Buildings* guide are:

- Part 1: Architect's guide
- Part 2: Concept design
- Part 3: Actions
- Part 4: Detailed design
- Part 5: Joint design
- Part 6: Fire Engineering
- Part 7: Model construction specification
- Part 8: Description of member resistance calculator
- Part 9: Description of simple connection resistance calculator
- Part 10: Guidance to developers of software for the design of composite beams

*Multi-Storey Steel Buildings* is one of two design guides. The second design guide is *Single-Storey Steel Buildings*.

The two design guides have been produced in the framework of the European project "Facilitating the market development for sections in industrial halls and low rise buildings (SECHALO) RFS2-CT-2008-0030".

The design guides have been prepared under the direction of Arcelor Mittal, Peiner Träger and Corus. The technical content has been prepared by CTICM and SCI, collaborating as the Steel Alliance.



# Contents

	<b>Page No</b>
FOREWORD	iii
SUMMARY	vi
1 INTRODUCTION	1
2 SAFETY PHILOSOPHY ACCORDING TO EN 1990	2
2.1 General format of the verifications	2
2.2 Ultimate limit states and serviceability limit states	2
2.3 Characteristic values and design values of actions	3
3 COMBINATIONS OF ACTIONS	4
3.1 General	4
3.2 ULS combinations	4
3.3 SLS combinations	6
4 PERMANENT ACTIONS	8
5 CONSTRUCTION LOADS	9
6 IMPOSED LOADS	10
6.1 General	10
6.2 Reduction due to the loaded area	10
6.3 Reduction due to the number of storeys	11
6.4 Horizontal loads on parapets	11
7 SNOW LOADS	12
8 WIND ACTION	13
8.1 General	13
8.2 Structural factor $c_s c_d$	13
9 EFFECT OF TEMPERATURE	18
REFERENCES	19
APPENDIX A Worked Example – Wind action on a multi-storey building	21

## **SUMMARY**

This document provides guidelines for the determination of the loads on a common multi-storey building, according to EN 1990 and EN 1991. After a short description of the general format for limit state design, this guide provides information on the determination of the permanent actions, the variable actions and the combinations of actions. This guide also includes a worked example on the wind action on a multi-storey building.



# 1 INTRODUCTION

This guide provides essential information on the determination of the design actions on a multi-storey building. It describes the basis of design with reference to the limit state concept in conjunction with the partial factor method, according to the following parts of the Eurocodes:

- EN 1990: Basis of structural design<sup>[1]</sup>
- EN 1991: Actions on structures
  - Part 1-1: General actions – Densities, self-weight, imposed loads for buildings<sup>[2]</sup>
  - Part 1-3: General actions – Snow loads<sup>[3]</sup>
  - Part 1-4: General actions – Wind actions<sup>[4]</sup>
  - Part 1-5: General actions – Thermal actions<sup>[5]</sup>
  - Part 1-6: General actions – Actions during execution.<sup>[6]</sup>

## **2 SAFETY PHILOSOPHY ACCORDING TO EN 1990**

### **2.1 General format of the verifications**

A distinction is made between ultimate limit states (ULS) and serviceability limit states (SLS).

The ultimate limit states are related to the following design situations:

- Persistent design situations (conditions of normal use)
- Transient design situations (temporary conditions applicable to the structure, e.g. during execution, repair, etc.)
- Accidental design situations (exceptional conditions applicable to the structure)
- Seismic design situations (conditions applicable to the structure when subjected to seismic events). These events are dealt with in EN 1998<sup>[7]</sup>, and are outside the scope of this guide.

The serviceability limit states concern the functioning of the structure under normal use, the comfort of people and the appearance of the construction.

The verifications shall be carried out for all relevant design situations and load cases.

### **2.2 Ultimate limit states and serviceability limit states**

#### **2.2.1 Ultimate limit states (ULS)**

The states classified as ultimate limit states are those that concern the safety of people and /or the safety of the structure. The structure shall be verified at ULS when there is:

- Loss of equilibrium of the structure or any part of it (EQU)
- Failure by excessive deformation, rupture, loss of stability of the structure or any part of it (STR)
- Failure or excessive deformation of the ground (GEO)
- Failure caused by fatigue or other time-dependent effects (FAT).

#### **2.2.2 Serviceability limit states (SLS)**

The structure shall be verified at SLS when there is:

- Deformations that affect the appearance, the comfort of users or the functioning of the structure
- Vibrations that cause discomfort to people or that limit the functional effectiveness of the structure
- Damage that is likely to adversely affect the appearance, the durability or the functioning of the structure.

## 2.3 Characteristic values and design values of actions

### 2.3.1 General

Actions shall be classified by their variation in time as follows:

- Permanent actions ( $G$ ), e.g. self-weight of structures, fixed equipment, etc.
- Variable actions ( $Q$ ), e.g. imposed loads, wind actions, snow loads, etc.
- Accidental actions ( $A$ ), e.g. explosions, impact from vehicles, etc.

Certain actions may be considered as either accidental and/or variable actions, e.g. seismic actions, snow loads, wind actions with some design situations.

### 2.3.2 Characteristic values of actions

The characteristic value ( $F_k$ ) of an action is its principal representative value. As it can be defined on statistical bases, it is chosen so as to correspond to a prescribed probability of not exceeding on the unfavourable side, during a “reference period” taking into account the design working life of the structure.

These characteristic values are specified in the various Parts of EN 1991.

### 2.3.3 Design values of actions

The design value  $F_d$  of an action  $F$  can be expressed in general terms as:

$$F_d = \gamma_f \psi F_k$$

where:

$F_k$  is the characteristic value of the action

$\gamma_f$  is a partial factor for the action

$\psi$  is either 1,00,  $\psi_0$ ,  $\psi_1$  or  $\psi_2$

### 2.3.4 Partial factors

Partial factors are used to verify the structures at ULS and SLS. They should be obtained from EN 1990 Annex A1, or from EN 1991 or from the relevant National Annex.

### 2.3.5 $\psi$ factors

In the combinations of actions,  $\psi$  factors apply to variable actions in order to take into account the reduced probability of simultaneous occurrence of their characteristic values.

The recommended values for  $\psi$  factors for buildings should be obtained from EN 1990 Annex A1 Table A1.1, or from EN 1991 or from the relevant National Annex.

## 3 COMBINATIONS OF ACTIONS

### 3.1 General

The individual actions should be combined so as not to exceed the limit state for the relevant design situations.

Actions that cannot occur simultaneously, e.g. due to physical reasons, should not be considered together in a same combination.

Depending on its uses and the form and the location of a building, the combinations of actions may be based on not more than two variable actions – See Note 1 in EN 1990 § A1.2.1(1). The National Annex may provide additional information.

### 3.2 ULS combinations

#### 3.2.1 Static equilibrium

To verify a limit state of static equilibrium of the structure (EQU), it shall be ensured that:

$$E_{d,dst} \leq E_{d,stab}$$

where:

$E_{d,dst}$  is the design value of the effect of destabilising actions

$E_{d,stab}$  is the design value of the effect of stabilising actions

#### 3.2.2 Rupture or excessive deformation of an element

To verify a limit state of rupture or excessive deformation of a section, member or connection (STR and/or GEO), it shall be ensured that:

$$E_d \leq R_d$$

where:

$E_d$  is the design value of the effect of actions

$R_d$  is the design value of the corresponding resistance

Each combination of actions should include a leading variable action or an accidental action.

#### 3.2.3 Combinations of actions for persistent or transient design situations

According to EN 1990 § 6.4.3.2(3), the combinations of actions can be derived either from expression (6.10) or from expressions (6.10a and 6.10b – whichever is more onerous). The choice between these two sets of expressions may be imposed by the National Annex.

In general, expression (6.10) is conservative in comparison to the pair of expressions (6.10a and 6.10b), but it leads to a reduced number of combinations to consider.

	Permanent actions		Leading variable action		Accompanying variable actions	
$E_d =$	$\sum_{j \geq 1} \gamma_{G,j} G_{k,j}$	+	$\gamma_{Q,1} Q_{k,1}$	+	$\sum_{i > 1} \gamma_{Q,i} \psi_{0,i} Q_{k,i}$	(6.10)

$E_d =$	$\sum_{j \geq 1} \gamma_{G,j} G_{k,j}$	+	$\psi_{0,1} \gamma_{Q,1} Q_{k,1}$	+	$\sum_{i > 1} \gamma_{Q,i} \psi_{0,i} Q_{k,i}$	(6.10a)
---------	--	---	-----------------------------------	---	--	---------

$E_d =$	$\xi \sum_{j \geq 1} \gamma_{G,j} G_{k,j}$	+	$\gamma_{Q,1} Q_{k,1}$	+	$\sum_{i > 1} \gamma_{Q,i} \psi_{0,i} Q_{k,i}$	(6.10b)
---------	--	---	------------------------	---	--	---------

$G_k$  and  $Q_k$  are found in EN 1991 or its National Annex.

$\gamma_G$  and  $\gamma_Q$  are found in Table A1.2(A) for static equilibrium (EQU); Tables A1.2(B) and A1.2(C) for rupture (STR and/or GEO) of EN 1990 or its National Annex.

**Table 3.1 Recommended values of partial factors**

Table (EN 1990)	Limit state	$\gamma_{G,inf}$	$\gamma_{G,sup}$	$\gamma_{Q,1} = \gamma_{Q,l}$	$\gamma_{Q,1} = \gamma_{Q,l}$
A1.2(A)	EQU	0,90	1,10	1,50	1,50
A1.2(B)	STR/GEO	1,00	1,35	1,50	1,50
A1.2(C)	STR/GEO	1,00	1,00	1,30	1,30

$\psi_0$  factors are found in EN 1990 Table A1.1 or in its National Annex. This factor varies between 0,5 and 1 except for roofs of category H ( $\psi_0 = 0$ ).

$\xi$  is a reduction factor for permanent loads. According to EN 1990 Table A1.2(B), the recommended value for buildings is  $\xi = 0,85$ . The National Annex may specify a different value.

For example, according to expression 6.10:

With snow as the leading variable action:

$$E_d = 1,35 G + 1,5 S + (1,5 \times 0,6) W = 1,35 G + 1,5 S + 0,9 W$$

With wind as the leading variable action:

$$E_d = 1,35 G + 1,5 W + (1,5 \times 0,5) S = 1,35 G + 1,5 W + 0,75 S$$

### 3.2.4 Combinations of actions for accidental design situations

Combinations of actions for accidental design situations should either involve an explicit accidental action or refer to a situation after an accident event.

	Permanent actions		Accidental action		Leading variable action		Accompanying variable actions
$E_d =$	$\sum_{j \geq 1} G_{k,j}$	+	$A_d$	+	$(\psi_{1,1} \text{ or } \psi_{2,1}) Q_{k,1}$	+	$\sum_{i > 1} \gamma_{Q,i} \psi_{0,i} Q_{k,i}$

The choice between  $\psi_{1,1}Q_{k,1}$  or  $\psi_{2,1}Q_{k,1}$  should be related to the relevant accidental design situation. Guidance is given in EN 1990 or in the National Annex to EN 1990.

### 3.3 SLS combinations

#### 3.3.1 Serviceability Limit State

To verify a serviceability limit state, it shall be ensured that:

$$E_d \leq C_d$$

where:

$E_d$  is the design value of the effects of actions specified in the serviceability criterion,

$C_d$  is the limiting design value of the relevant serviceability criterion.

#### 3.3.2 Characteristic combination

The characteristic combination is normally used for irreversible limit states.

	Permanent actions		Leading variable action		Accompanying variable actions
$E_d =$	$\sum_{j \geq 1} G_{k,j}$	+	$Q_{k,1}$	+	$\sum_{i > 1} \psi_{0,i} Q_{k,i}$

For example, with snow as the leading variable action:

$$E_d = G + S + 0,6 W$$

$$E_d = G + S + 0,7 Q \quad (Q \text{ being the imposed load in an office building})$$

#### 3.3.3 Frequent combination

The frequent combination is normally used for reversible limit states.

	Permanent actions		Leading variable action		Accompanying variable actions
$E_d =$	$\sum_{j \geq 1} G_{k,j}$	+	$\psi_{1,1} Q_{k,1}$	+	$\sum_{i > 1} \psi_{2,i} Q_{k,i}$

For example, with snow as the leading variable action:

$$E_d = G + 0,2 S \quad (\psi_2 = 0 \text{ for the wind action})$$

$$E_d = G + 0,2 S + 0,3 Q \quad (Q \text{ being the imposed load in an office building})$$

### 3.3.4 Quasi-permanent combination

The quasi-permanent combination is normally used for long-term effects and the appearance of the structure.

	Permanent actions	+	Variable actions
$E_d =$	$\sum_{j \geq 1} G_{k,j}$		$\sum_{i > 1} \psi_{2,i} Q_{k,i}$

For example:

$$E_d = G + 0,3 Q \quad (Q \text{ being the imposed load in an office building})$$

### 3.3.5 Floor vibration

In multi-storey buildings, floor vibration is sometimes a serviceability limit state that is critical in the design. There is no specific rule in the Eurocodes. Limits may be given in the National Annexes.

A simple rule is generally to require the frequency to be higher than a minimum value (3 or 5 Hz for example); the frequency being assessed from the total permanent loads and a fraction of the imposed loads  $I$  (for example:  $G + 0,2 I$ ). This approach is often too conservative and more advanced methods are available, see the *Design guide for floor vibrations*<sup>[8]</sup>. additional information is given in *Multi-storey steel buildings. Part 4: Detailed design*<sup>[9]</sup>.

## 4 PERMANENT ACTIONS

The self-weight of construction works is generally the main permanent load. As stated in EN 1991-1-1 § 2.1(1), it should be classified as a permanent fixed action

The total self-weight of structural and non-structural members, including fixed services, should be taken into account in combinations of actions as a single action.

Non-structural elements include roofing, surfacing and coverings, partitions and linings, hand rails, safety barriers, parapets, wall claddings, suspended ceilings, thermal insulation, fixed machinery and all fixed services (equipment for lifts and moving stairways, heating, ventilating, electrical and air conditioning equipment, pipes without their contents, cable trunking and conduits).

The characteristic values of self-weight should be defined from the dimensions and densities of the elements.

Values of densities of construction materials are provided in EN 1991-1-1 Annex A (Tables A.1 to A.5).

For example:

Steel:  $\gamma = 77,0$  to  $78,5$  kN/m<sup>3</sup>

Normal reinforced concrete  $\gamma = 25,0$  kN/m<sup>3</sup>

Aluminium:  $\gamma = 27,0$  kN/m<sup>3</sup>

For manufactured elements (façades, ceilings and other equipment for buildings), data may be provided by the manufacturer.



## 5 CONSTRUCTION LOADS

EN 1991-1-6 gives rules for the determination of actions during execution. Verifications are required for both serviceability limit states and ultimate limit states.

Table 4.1 defines construction loads that have to be taken into account:

- Personnel and hand tools ( $Q_{ca}$ )
- Storage of movable items ( $Q_{cb}$ )
- Non permanent equipment ( $Q_{cc}$ )
- Moveable heavy machinery and equipment ( $Q_{cd}$ )
- Accumulation of waste material ( $Q_{ce}$ )
- Loads from parts of structure in a temporary state ( $Q_{cf}$ ).

Recommended values are provided in the same table but values may be given in the National Annex.

In multi-storey buildings, the design of composite floors or composite beams should be carried out with reference to EN 1991-1-6 § 4.11.2 for the determination of the construction loads during the casting of concrete.

## 6 IMPOSED LOADS

### 6.1 General

Generally, imposed loads on buildings shall be classified as variable free actions. They arise from occupancy. They include normal use by persons, furniture and moveable objects, vehicles, anticipating rare events (concentrations of persons or of furniture, momentary moving or stacking of objects, etc.). Movable partitions should be treated as imposed loads.

Imposed loads are represented by uniformly distributed loads, line loads or point loads applied on roofs or floors, or a combination of these loads.

Floor and roof areas in buildings are sub-divided into categories according to their use (Table 6.1). The characteristic values  $q_k$  (uniformly distributed load) and  $Q_k$  (concentred load) related to these categories are specified in Table 6.2 (or in the National Annex).

For the design of a single floor or a roof, the imposed load shall be taken into account as a free action applied at the most unfavourable part of the influence area of the action effects considered.

Where the loads on other storeys are relevant, they may be assumed to be distributed uniformly (fixed actions).

Characteristic values of imposed loads are specified in EN 1991-1-1 Section 6.3 as follows:

6.3.1 Residential, social, commercial and administration areas

6.3.2 Areas for storage and industrial activities

6.3.3 Garages and vehicle traffic areas

6.3.4 Roofs.

### 6.2 Reduction due to the loaded area

In multi-storey buildings, the characteristic value  $q_k$  of the imposed loads on floors and accessible roofs may be reduced by a factor  $\alpha_A$ , for categories A to D, where:

$$\alpha_A = \frac{5}{7}\psi_0 + \frac{A_0}{A} \leq 1,0$$

With the restriction for categories C and D:  $\alpha_A \geq 0,6$

where:

$\psi_0$  is the factor as defined in EN 1990 Annex A1 Table A1.1.

$A_0 = 10 \text{ m}^2$

$A$  is the loaded area

The National Annex may give an alternative method.

### 6.3 Reduction due to the number of storeys

For the design of columns and walls, loaded from several storeys, the total imposed loads on the floor of each storey should be assumed to be distributed uniformly.

For columns and walls, the total imposed loads may be reduced by a factor  $\alpha_n$ , for categories A to D, where:

$$\alpha_n = \frac{2 + (n - 2)}{n} \psi_0$$

where:

$\psi_0$  is the factor as defined in EN 1990 Annex A1 Table A1.1.

$n$  is the number of storeys ( $> 2$ ) above the loaded structural elements in the same category.

The National Annex may give an alternative method.

### 6.4 Horizontal loads on parapets

The characteristic values of the line loads  $q_k$  acting at the height of the partition walls or parapets but not higher than 1,20 m should be taken from EN 1991-1-1 Table 6.12, which provides recommended values. Other values may be given in the National Annex.

For areas susceptible to significant overcrowding associated with public events (stages, assembly halls, conference rooms), the load should be taken according to category C5 from EN 1991-1-1 Table 6.1.

For office buildings (category B), the recommended value from EN 1991-1-1 Table 6.12 is:

$$q_k = 0,2 \text{ to } 1,0 \text{ kN/m}$$

The National Annex may define other values.

## 7 SNOW LOADS

There is no issue in the calculation of snow loads specifically related to multi-storey buildings. Full information including a worked example is provided in *Single-storey steel buildings. Part 3: Actions*<sup>[10]</sup>.

## 8 WIND ACTION

### 8.1 General

The determination of the wind action according to EN 1991-1-4<sup>[4]</sup> is described in *Single-storey steel buildings. Part 3:– Actions* <sup>[10]</sup> for a single storey building. For a multi-storey building, the calculation is nearly the same, except for two aspects:

- The calculation of the structural factor  $c_s c_d$
- For slender buildings, the external pressure coefficients must be calculated for different strips along the height of the building.

According to EN 1991-1-4 § 6.2(1), the structural factor may be taken equal to 1 when the height of the building is lower than 15 m, which is commonly the case for single storey buildings. For multi-storey buildings, which are commonly higher than 15 m, the structural factor has to be determined. Section 8.2 provides the main steps of this calculation according to EN 1991-1-4 § 6.3.1(1).

A detailed example including the full calculation of the wind action on a multi-storey building is given in Appendix A.

### 8.2 Structural factor $c_s c_d$

The structural factor  $c_s c_d$  should be calculated for the main wind directions, using the equation given EN 1991-1-4 § 6.3.1(1), provided that:

- The building shape is a rectangular, parallel sided as stated in EN 1991-1-4 § 6.3.1(2) and Figure 6.1
- The along-wind vibration in the fundamental mode is significant and the mode shape has a constant sign.

This calculation requires the determination of several intermediate parameters.

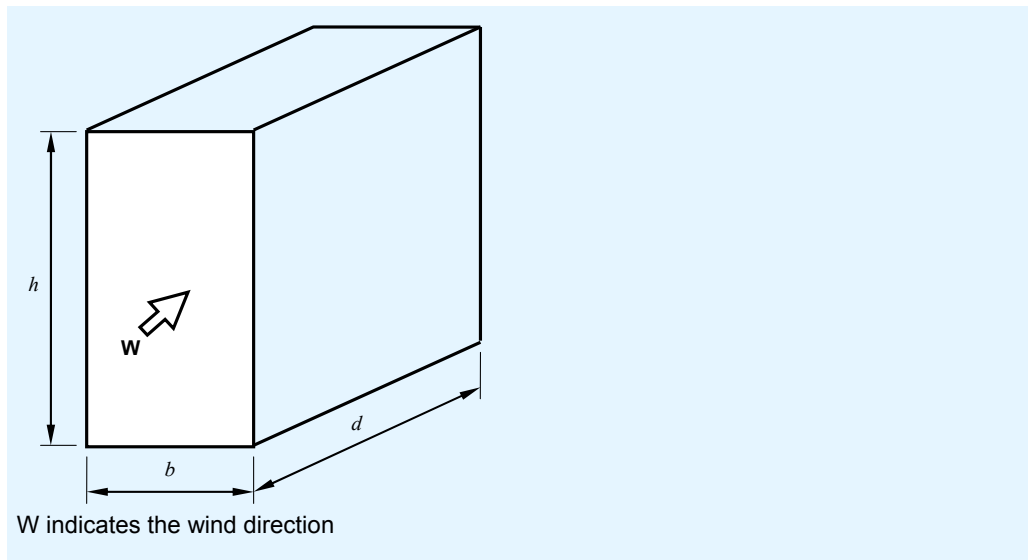

**Figure 8.1 General dimensions of a building**

The following procedure is proposed:

1. The roughness length  $z_0$  and the minimum height  $z_{\min}$

These values are obtained from EN 1991-1-4 Table 4.1, depending on the terrain category.

2. The reference height  $z_s$

$$z_s = 0,6 h \text{ (} h \text{ is the height of the multi-storey building)}$$

But  $z_s$  should not be taken lower than  $z_{\min}$ .

3. The orography factor  $c_o(z_s)$

According to EN 1991-1-4 § 4.3.3, the effects of orography may be neglected when the average slope of the upwind terrain is less than  $3^\circ$ .

Then:

$$c_o(z_s) = 1,0$$

Otherwise, this factor can be determined either from EN 1991-1-4 §A.3, or from the relevant National Annex.

4. The roughness factor  $c_r(z_s)$

$c_r(z_s)$  has to be calculated for the reference height according to EN 1991-1-4 § 4.3.2:

$$\text{If } z_{\min} \leq z_s \leq z_{\max} \quad c_r(z_s) = 0,19 (z_0/z_{0,II})^{0,07} \ln(z_s/z_0)$$

$$\text{Else, if } z_s < z_{\min} \quad c_r(z_s) = c_r(z_{\min})$$

where:  $z_{0,II} = 0,05 \text{ m}$  and  $z_{\max} = 200 \text{ m}$

5. The turbulence factor  $k_1$

It may be defined by the National Annex. The recommended value is:

$$k_1 = 1,0$$

### Part 3: Actions

6. The turbulence intensity  $I_v(z_s)$

$$\text{If } z_{\min} \leq z_s \leq z_{\max} \quad I_v(z_s) = k_1 / [c_0(z_s) \ln(z_s/z_0) ]$$

$$\text{Else, if } z_s < z_{\min} \quad I_v(z_s) = I_v(z_{\min})$$

where:  $z_{\max} = 200$  m

7. The turbulent length scale  $L(z_s)$

$$\text{If } z_{\min} \geq z_s \quad L(z_s) = L_t (z_s/z_t)^\alpha$$

$$\text{Else, if } z_s < z_{\min} \quad L(z_s) = L(z_{\min})$$

where:  $\alpha = 0,67 + 0,05 \ln(z_0)$  [ $z_0$  in meters]

$$L_t = 300 \text{ m}$$

$$z_t = 200 \text{ m}$$

Note: Some of the following parameters are determined using EN 1991-1-4 Annex B as recommended method. They can also be defined by the National Annex.

8. The background factor  $B^2$

$$B^2 = \frac{1}{1 + 0,9 \left( \frac{b+h}{L(z_s)} \right)^{0,63}}$$

9. The mean wind velocity  $v_m(z_s)$

The mean wind velocity at the reference height  $z_s$  is calculated from:

$$v_m(z_s) = c_0(z_s) c_r(z_s) v_b$$

Where  $v_b$  is the basic wind velocity as defined in EN 1991-1-4 § 4.2(2).

10. The fundamental frequency  $n_{1,x}$

The procedure requires the determination of the fundamental frequency of the building in the wind direction. The following formula can be used for common buildings in order to get a rough estimation of the fundamental frequency in Hertz:

$$n_{1,x} = \frac{\sqrt{d}}{0,1h}$$

With  $d$  and  $h$  in meters.

Complementary information can be found in the ECCS recommendations for calculating the effect of wind on constructions<sup>[11]</sup>.

11. The non-dimensional power spectral density function  $S_L(z_s, n_{1,x})$

$$S_L(z_s, n_{1,x}) = \frac{6,8 f_L(z_s, n_{1,x})}{[1 + 10,2 f_L(z_s, n_{1,x})]^{5/3}}$$

$$\text{where: } f_L(z_s, n_{1,x}) = \frac{n_{1,x} L(z_s)}{v_m(z_s)}$$

12. The logarithmic decrement of structural damping  $\delta_s$

$\delta_s = 0,05$  for a steel building (EN 1991-1-4 Table F.2).

13. The logarithmic decrement of aerodynamic damping  $\delta_a$

The logarithmic decrement of aerodynamic damping for the fundamental mode is calculated according to EN 1991-1-4 § F.5(4):

$$\delta_a = \frac{c_f \rho b v_m(z_s)}{2 n_{1,x} m_e}$$

where:

$c_f$  is the force coefficient in the wind direction

$$c_f = c_{f,0} \psi_r \psi_\lambda \quad (\text{EN-1991-1-4 § 7.6(1)})$$

For common buildings, the reduction factors  $\psi_r$  and  $\psi_\lambda$  can be taken equal to 1,0.

$c_{f,0}$  is obtained from EN 1991-1-4 Figure 7.23.

$\rho$  is the air density as defined in EN 1991-1-4 § 4.5(1). The recommended value is:  $\rho = 1,25 \text{ kg/m}^3$

$m_e$  is the equivalent mass per unit length according to EN 1991-1-4 § F.4. For a multi-storey building, when the mass is approximately the same for all the storeys, it can be taken equal to the mass per unit length  $m$ .  $m_e$  is therefore the total mass of the building divided by its height.

14. The logarithmic decrement of damping due to special devices  $\delta_d$

$\delta_d = 0$  when no special device is used.

15. The logarithmic decrement  $\delta$

$$\delta = \delta_s + \delta_a + \delta_d$$

16. The aerodynamic admittance functions  $R_h$  and  $R_b$

They are calculated using the equation given in EN 1991-1-4 § B.2(6) in function of parameters defined above:  $b, h, L(z_s), f_L(z_s, n_{1,x})$ .

17. The resonance response factor  $R^2$

$$R^2 = \frac{\pi^2}{2\delta} S_L(z_s, n_{1,x}) \times R_h \times R_b$$

18. The peak factor  $k_p$

The peak factor can be calculated as (EN 1991-1-4 § B.2(3)):



Part 3: Actions

$$k_p = \text{Max} \left( \sqrt{2 \times \ln(vT)} + \frac{0,6}{\sqrt{2 \times \ln(vT)}} ; 3,0 \right)$$

where:

$$v = \text{Max} \left( n_{1,x} \times \sqrt{\frac{R^2}{B^2 + R^2}} ; 0,08 \text{ Hz} \right)$$

$T$  is the averaging time for the mean wind velocity:  $T = 600 \text{ s}$

19. Finally, the structural factor  $c_s c_d$  can be calculated:

$$c_s c_d = \frac{1 + 2 k_p I_v(z_s) \sqrt{B^2 + R^2}}{1 + 7 I_v(z_s)}$$

## 9 EFFECT OF TEMPERATURE

Buildings not exposed to daily or seasonal climatic changes may not need to be assessed under thermal actions. For large buildings, it is generally good practice to design the building with expansion joints so that the temperature changes do not induce internal forces in the structure. Information about the design of expansion joints is given in Section 6.4 of *Multi-storey steel buildings. Part 2: Concept design*<sup>[12]</sup>.

When the effects of temperature have to be taken into account, EN 1993-1-5<sup>[5]</sup> provides rules to determine them.

## REFERENCES

- 1 EN 1990:2002: Eurocode Basis of structural design
- 2 EN 1991-1-1:2002: Eurocode 1 Actions on structures. General actions. Densities, self-weight, imposed loads for buildings
- 3 EN 1991-1-3:2003: Eurocode 1 Actions on structures. General actions. Snow loads
- 4 EN 1991-1-4:2005: Eurocode 1 Actions on structures. General actions. Wind actions
- 5 EN 1991-1-5:2003: Eurocode 1 Actions on structures. General actions. Thermal actions
- 6 EN 1991-1-6:2005: Eurocode 1 Actions on structures. General actions. Actions during execution.
- 7 EN 1998-1:2004: Eurocode 8 Design of structures for earthquake resistance. General rules, seismic actions and rules for buildings
- 8 HECHLER, O., FELDMANN, M., HEINEMEYER, C. and GALANTI, F. Design guide for floor vibrations Eurosteel 2008.
- 9 Steel Buildings in Europe  
Multi-storey steel buildings. Part 4: Detailed design
- 10 Steel Buildings in Europe  
Single-storey steel buildings. Part 3: Actions
- 11 Recommendations for calculating the effect of wind on constructions  
Publication No. 52. 1987. ECCS-CECM-EKS  
(Available on the web site: [www.steel-construct.com](http://www.steel-construct.com))
- 12 Recommendations for calculating the effect of wind on constructions  
Publication No. 52. 1987. ECCS-CECM-EKS  
(Available on the web site: [www.steel-construct.com](http://www.steel-construct.com))



## **APPENDIX A**

### **Worked Example: Wind action on a multi-storey building**

## 1. Data

This worked example deals with the determination of the wind action on a multi-storey building according to EN 1991-1-4.

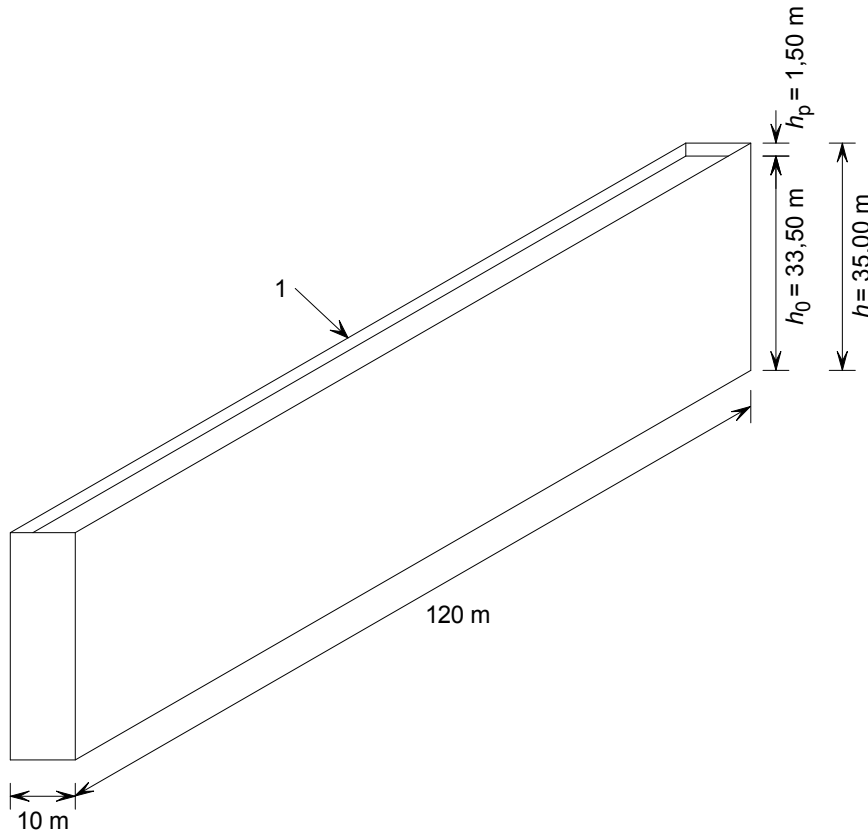

1 Parapet

**Figure A.1 Dimensions of the building**

The building is erected on a suburban terrain where the average slope of the upwind terrain is low ( $3^\circ$ ).

The terrain roughness is the same all around and there are no large and tall buildings in the neighbourhood.

The fundamental value of the basic wind velocity is:

$$V_{b,0} = 26 \text{ m/s}$$

The roof slope is such that:  $\alpha < 5^\circ$

Title	Appendix A Worked Example: Wind action on a multi-storey building	2 of 18
<p><b>2. Peak velocity pressure</b></p> <p><b>2.1. General</b></p> <p>For a multi-storey building, the peak velocity pressure generally depends on the wind direction because the height of the building is higher than the width of the upwind face. Therefore we have to distinguish between:</p> <ul style="list-style-type: none"> <li>• Wind on the long side</li> <li>• Wind on the gable</li> </ul> <p>The calculation of the peak velocity pressure is performed according to the detailed procedure described in Section 7.2.1 of <i>Single-storey steel buildings. Part 3: Actions</i><sup>[10]</sup>.</p> <p><b>2.2. Wind on the long side</b></p> <p><b>1 Fundamental value of the basic wind velocity</b></p> $v_{b,0} = 26 \text{ m/s}$ <p><b>2 Basic wind velocity</b></p> $v_b = c_{dir} c_{season} v_{b,0}$ <p>For <math>c_{dir}</math> and <math>c_{season}</math>, the recommended values are:</p> $c_{dir} = 1,0$ $c_{season} = 1,0$ <p>Then: <math>v_b = v_{b,0} = 26 \text{ m/s}</math></p> <p><b>3 Basic velocity pressure</b></p> $q_b = \frac{1}{2} \rho v_b^2$ <p>where:</p> $\rho = 1,25 \text{ kg/m}^3$ <p>Then: <math>q_b = 0,5 \times 1,25 \times 26^2 = 422,5 \text{ N/m}^2</math></p> <p><b>4 Terrain factor</b></p> $k_r = 0,19 (z_0 / z_{0,II})^{0,07}$ <p>The terrain category is III. Then:</p> $z_0 = 0,3 \text{ m (and } z_{min} = 5 \text{ m)}$ $z_{0,II} = 0,05 \text{ m}$ <p>Then: <math>k_r = 0,19 \times (0,3 / 0,05)^{0,07} = 0,215</math></p> <p><b>5 Roughness factor</b></p> $c_r(z) = k_r \ln(z/z_0) \quad \text{for: } z_{min} \leq z \leq z_{max}$ $c_r(z) = c_r(z_{min}) \quad \text{for: } z \leq z_{min}$		

EN 1991-1-4  
§ 4.2(2)

EN 1991-1-4  
§ 4.5(1)

EN 1991-1-4  
§ 4.3.2(1)

EN 1991-1-4  
§ 4.3.2

Title	Appendix A Worked Example: Wind action on a multi-storey building	3 of 18
<p>where:</p> <p><math>z_{\max} = 200 \text{ m}</math></p> <p><math>z</math> is the reference height</p> <p>The total height of the building is: <math>h = 35 \text{ m}</math></p> <p>The width of the wall is: <math>b = 120 \text{ m}</math></p> <p><math>h \leq b</math> therefore <math>q_p(z) = q_p(z_e)</math> with: <math>z_e = h = 35 \text{ m}</math></p> <p>Therefore <math>c_r(z) = 0,215 \times \ln(35/0,3) = 1,023</math></p> <p><b>6 Orography factor</b></p> <p>Since the slope of the terrain is lower than <math>3^\circ</math>, the recommended value is used:</p> <p><math>c_o(z) = 1,0</math></p> <p><b>7 Turbulence factor</b></p> <p>The recommended value is used:</p> <p><math>k_1 = 1,0</math></p> <p><b>8 Peak velocity pressure</b></p> <p><math>q_p(z) = [1 + 7 I_v(z)] \times 0,5 \rho v_m^2(z)</math></p> <p>where:</p> <p><math>\rho = 1,25 \text{ kg/m}^3</math> (recommended value)</p> <p><math>v_m(z)</math> is the mean wind velocity at height <math>z</math> above the terrain</p> $v_m(z) = c_r(z) c_o(z) v_b$ $= 1,023 \times 1,0 \times 26$ $= 26,6 \text{ m/s}$ <p><math>I_v(z)</math> is the turbulence intensity</p> $I_v(z) = k_1 / [c_o(z) \ln(z/z_0)] \quad \text{for: } z_{\min} \leq z \leq z_{\max}$ $I_v(z) = I_v(z_{\min}) \quad \text{for: } z \leq z_{\min}$ <p>Then: <math>I_v(z) = 1,0 / [1,0 \times \ln(35/0,3)] = 0,21</math></p> $q_p(z) = [1 + 7 \times 0,21] \times 0,5 \times 1,25 \times 26,6^2 \times 10^{-3}$ $= 1,09 \text{ kN/m}^2$ <p><b>2.3. Wind on the gable</b></p> <p>Several parameters are identical to the case of wind on the long side, as follows:</p> <p><b>1 Fundamental value of the basic wind velocity</b></p> <p><math>v_{b,0} = 26 \text{ m/s}</math></p> <p><b>2 Basic wind velocity</b></p> <p><math>v_b = 26 \text{ m/s}</math></p>		<p>EN 1991-1-4 Figure 7.4</p> <p>EN 1991-1-4 § 4.3.3</p> <p>EN 1991-1-4 § 4.4(1)</p> <p>EN 1991-1-4 § 4.5(1)</p> <p>EN 1991-1-4 § 4.2(2)</p>



Title	Appendix A Worked Example: Wind action on a multi-storey building	4 of 18																																									
<p><b>3 Basic velocity pressure</b>  <math>q_b = 422,5 \text{ N/m}^2</math></p> <p><b>4 Terrain factor</b>  <math>k_r = 0,215</math></p> <p><b>5 Roughness factor</b>            The total height of the building is: <math>h = 35 \text{ m}</math>            The width of the wall is: <math>b = 10 \text{ m}</math>  <math>h &gt; 2b</math>            Therefore several strips are considered:            - The lower strip between 0 and <math>b = 10 \text{ m}</math>            - The upper strip between <math>(h - b) = 25 \text{ m}</math> and <math>h = 35 \text{ m}</math>            Intermediate strips with a height taken equal to: <math>h_{\text{strip}} = 5 \text{ m}</math>            The values of <math>c_r(z)</math> are given in Table A.1.</p> <p><b>6 Orography factor</b>  <math>c_o(z) = 1,0</math></p> <p><b>7 Turbulence factor</b>  <math>k_l = 1,0</math></p> <p><b>8 Peak velocity pressure</b>            The peak velocity pressure is calculated for each strip, with <math>z = z_e</math> which is the position of the top of the strip (see Table A.1).</p> <p><b>Table A.1 Peak velocity pressure – Wind on the gable</b></p> <table border="1" data-bbox="188 1310 1034 1572"> <thead> <tr> <th></th> <th><math>z_e</math></th> <th><math>c_r(z)</math></th> <th><math>v_m(z)</math> m/s</th> <th><math>l_v(z)</math></th> <th><math>q_p(z)</math> kN/m<sup>2</sup></th> </tr> </thead> <tbody> <tr> <td></td> <td>0</td> <td>10 m</td> <td>0,75</td> <td>19,5</td> <td>0,29</td> <td>0,72</td> </tr> <tr> <td></td> <td>10 m</td> <td>15 m</td> <td>0,84</td> <td>21,8</td> <td>0,26</td> <td>0,84</td> </tr> <tr> <td></td> <td>15 m</td> <td>20 m</td> <td>0,90</td> <td>23,4</td> <td>0,24</td> <td>0,92</td> </tr> <tr> <td></td> <td>20 m</td> <td>25 m</td> <td>0,95</td> <td>24,7</td> <td>0,23</td> <td>1,00</td> </tr> <tr> <td></td> <td>25 m</td> <td>35 m</td> <td>1,02</td> <td>26,5</td> <td>0,21</td> <td>1,09</td> </tr> </tbody> </table>		$z_e$	$c_r(z)$	$v_m(z)$ m/s	$l_v(z)$	$q_p(z)$ kN/m <sup>2</sup>		0	10 m	0,75	19,5	0,29	0,72		10 m	15 m	0,84	21,8	0,26	0,84		15 m	20 m	0,90	23,4	0,24	0,92		20 m	25 m	0,95	24,7	0,23	1,00		25 m	35 m	1,02	26,5	0,21	1,09	<p>§ 4.5(1)</p> <p>§ 4.3.2(1)</p> <p>§ 4.3.2            EN 1991-1-4            Figure 7.4</p> <p>EN 1991-1-4            § 4.3.3</p> <p>§ 4.4(1)</p>	
	$z_e$	$c_r(z)$	$v_m(z)$ m/s	$l_v(z)$	$q_p(z)$ kN/m <sup>2</sup>																																						
	0	10 m	0,75	19,5	0,29	0,72																																					
	10 m	15 m	0,84	21,8	0,26	0,84																																					
	15 m	20 m	0,90	23,4	0,24	0,92																																					
	20 m	25 m	0,95	24,7	0,23	1,00																																					
	25 m	35 m	1,02	26,5	0,21	1,09																																					

Title	Appendix A Worked Example: Wind action on a multi-storey building	5 of 18
<p><b>3. Wind pressure</b></p> <p><b>3.1. External pressure coefficients</b></p> <p><b>3.1.1. Vertical walls</b></p> <p>Wind on the long side:</p> <p><math>b = 120</math> m (crosswind dimension)</p> <p><math>d = 10</math> m</p> <p><math>h = 35</math> m</p> <p><math>h / d = 3,5</math></p> <p><math>e = \text{Min}(b ; 2 h) = 70</math> m</p> <p>Zone A (gables): <math>c_{pe,10} = -1,2 (e &gt; 5d)</math></p> <p>Zone D (upwind): <math>c_{pe,10} = +0,8</math></p> <p>Zone E (downwind): <math>c_{pe,10} = -0,6</math></p> <p>Wind on the gable:</p> <p><math>b = 10</math> m (crosswind dimension)</p> <p><math>d = 120</math> m</p> <p><math>h = 35</math> m</p> <p><math>h / d = 0,29</math></p> <p><math>e = \text{Min}(b ; 2 h) = 10</math> m</p> <p><u>Long sides:</u></p> <p>Zone A: <math>c_{pe,10} = -1,2 (e &lt; d)</math> along <math>e/5 = 2</math> m</p> <p>Zone B: <math>c_{pe,10} = -0,8</math> along <math>4/5 e = 8</math> m</p> <p>Zone C: <math>c_{pe,10} = -0,5</math></p> <p><u>Gables</u> (<math>h/d \approx 0,25</math>):</p> <p>Zone D (upwind): <math>c_{pe,10} = +0,7</math></p> <p>Zone E (downwind): <math>c_{pe,10} = -0,3</math> (by linear interpolation)</p> <p><b>3.1.2. Flat roof with parapets</b></p> <p>The external pressure coefficients depend on the ratio:</p> <p><math>h_p / h_0 = 1,50 / 33,50 = 0,045</math></p> <p>Wind on the long side:</p> <p><math>e = \text{Min}(b = 120 \text{ m} ; 2 h_0 = 67 \text{ m}) = 67</math> m</p> <p>The external pressure coefficients are given in Figure A.2 for wind on the long side.</p>		<p>EN 1991-1-4 § 7.2.2(2) Figure 7.5 Table 7.1</p> <p>EN 1991-1-4 § 7.2.2(2) Figure 7.5 Table 7.1</p> <p>EN 1991-1-4 § 7.2.3 Figure 7.6 Table 7.2</p>

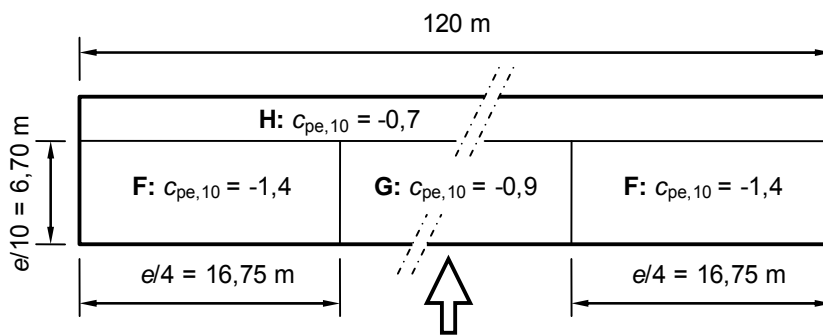
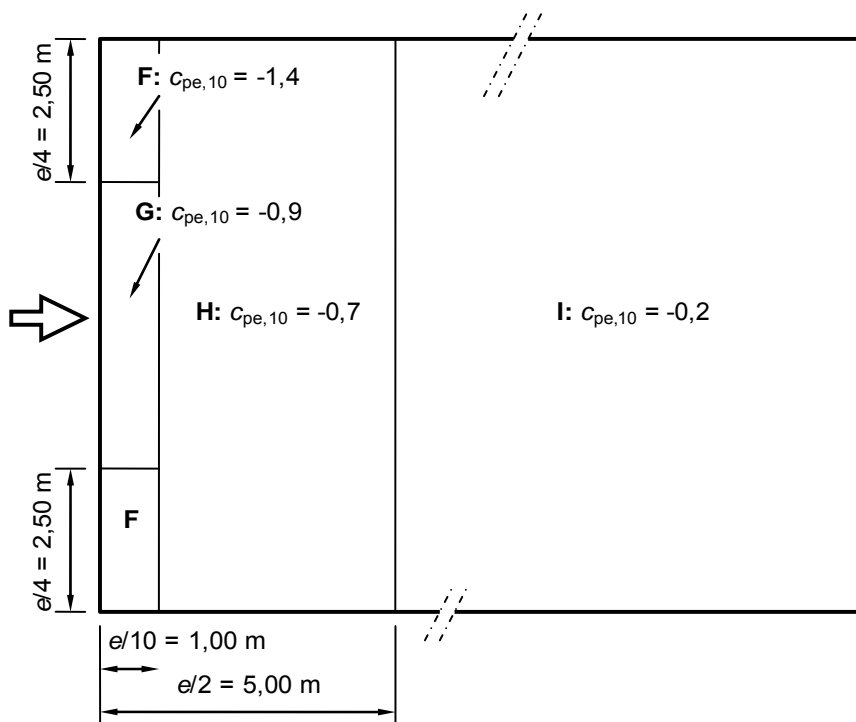

**Figure A.2 External pressure coefficients on the roof – Wind on the long side**

Wind on the gable:

$$e = \text{Min}(b = 10 \text{ m} ; 2 h_0 = 67 \text{ m}) = 10 \text{ m}$$

The external pressure coefficients are given in Figure A.3 for wind on a gable.



**Figure A.3 External pressure coefficients on the roof – Wind on the gable**

Title	Appendix A Worked Example: Wind action on a multi-storey building	7 of 18
<p><b>3.2. Structural factor</b></p> <p><b>3.2.1. General</b></p> <p>The structural factor <math>c_s c_d</math> is calculated from the following equation, for wind on the long side and for wind on the gable:</p> $c_s c_d = \frac{1 + 2 k_p I_v(z_s) \cdot \sqrt{B^2 + R^2}}{1 + 7 I_v(z_s)}$ <p>The calculation is performed according to the procedure given in Section 8.2 of this guide.</p> <p><b>3.2.2. Wind on the long side</b></p> <p>Dimensions: <math>b = 120</math> m and <math>h = 35</math> m</p> <p><b>1 The terrain category is III.</b> Then: <math>z_0 = 0,30</math> m and <math>z_{\min} = 5</math> m</p> <p><b>2 Reference height:</b> <math>z_s = 0,6 h = 0,6 \times 35 = 21</math> m (<math>&gt; z_{\min} = 5</math> m)</p> <p><b>3 Orography factor</b> Since the slope of the upwind terrain is less than <math>3^\circ</math>, <math>c_0(z_s) = 1,0</math></p> <p><b>4 Roughness factor</b> Since <math>z_{\min} \leq z_s \leq z_{\max} (= 200</math> m) <math>c_r(z_s) = 0,19 (z_0/z_{0,II})^{0,07} \ln(z_s/z_0)</math> <math>= 0,19 \times (0,3 / 0,05)^{0,07} \times \ln(21/0,3)</math> <math>= 0,915</math></p> <p><b>5 Turbulence factor (recommended value):</b> <math>k_1 = 1,0</math></p> <p><b>6 Turbulence intensity</b> Since <math>z_{\min} \leq z_s \leq z_{\max} (= 200</math> m) <math>I_v(z_s) = k_1 / [c_0(z_s) \ln(z_s/z_0)]</math> <math>= 1,0 / [1,0 \times \ln(21 / 0,3)]</math> <math>= 0,235</math></p> <p><b>7 Turbulent length scale</b> Since <math>z_s &gt; z_{\min}</math>: <math>L(z_s) = L_t (z_s/z_t)^\alpha</math> <math>L_t = 300</math> m <math>z_t = 200</math> m <math>\alpha = 0,67 + 0,05 \ln(z_0) = 0,67 + 0,05 \ln(0,30) = 0,61</math> Then: <math>L(z_s) = 300 \times (21/200)^{0,61} = 75,9</math> m</p>		

EN 1991-1-4  
§ 6.3.1

EN 1991-1-4  
Table 4.1

EN 1991-1-4  
Figure 6.1

EN 1991-1-4  
§ 4.3.3

EN 1991-1-4  
§ 4.3.2

EN 1991-1-4  
§ 4.4(1)

EN 1991-1-4  
§ 4.4(1)

EN 1991-1-4  
§ B.1(1)

Title	Appendix A Worked Example: Wind action on a multi-storey building	8 of 18
<p><b>8 Background factor</b></p> $B^2 = \frac{1}{1 + 0,9 \left( \frac{b+h}{L(z_s)} \right)^{0,63}} = \frac{1}{1 + 0,9 \left( \frac{120 + 35}{75,9} \right)^{0,63}} = 0,415$	<p><b>9 Mean wind velocity at the reference height <math>z_s</math></b></p> $v_m(z_s) = c_r(z_s) c_0(z_s) v_b$ $= 0,915 \times 1,0 \times 26 = 23,8 \text{ m/s}$ <p><b>10 Fundamental frequency <math>n_{1,x}</math></b></p> <p>It is estimated by the simplified formula: <math>n_{1,x} = \frac{\sqrt{d}}{0,1 h}</math></p> $n_{1,x} = \frac{\sqrt{10}}{0,1 \times 35} = 0,9 \text{ Hz}$ <p><b>11 Non dimensional power spectral density function</b></p> $S_L(z_s, n_{1,x}) = \frac{6,8 f_L(z_s, n_{1,x})}{(1 + 10,2 f_L(z_s, n_{1,x}))^{5/3}}$ $f_L(z_s, n_{1,x}) = \frac{n_{1,x} L(z_s)}{v_m(z_s)}$ $f_L(z_s, n_{1,x}) = \frac{0,9 \times 75,9}{23,8} = 2,87$ <p>Then: <math>S_L(z, n) = \frac{6,8 \times 2,87}{(1 + 10,2 \times 2,87)^{5/3}} = 0,0664</math></p>	<p>EN 1991-1-4 § B.2(2)</p> <p>EN 1991-1-4 § 4.3.1</p> <p>EN 1991-1-4 § B.1(2)</p> <p>EN 1991-1-4 § F.5(2) Table F.2</p> <p>EN 1991-1-4 § F.5(4)</p> <p>EN 1991-1-4 § F.5(1)</p>
<p><b>12 Logarithmic decrement of structural damping</b></p>	$\delta_s = 0,05$	
<p><b>13 Logarithmic decrement of aerodynamic damping <math>\delta_a</math></b></p>	$\delta_a = \frac{c_f \rho b v_m(z_s)}{2 n_{1,x} m_e}$ $\rho = 1,25 \text{ kg/m}^3$ $c_f = c_{f,0} = 2,0 \text{ for } d/b = 10/120 = 0,083$ <p><math>m_e</math> is the equivalent mass per unit length: <math>m_e = 150 \text{ t/m}</math></p> <p>Therefore: <math>\delta_a = \frac{2 \times 1,25 \times 120 \times 23,8}{2 \times 0,9 \times 150 \times 10^3} = 0,026</math></p>	
<p><b>14 Logarithmic decrement of damping due to special devices</b></p>	$\delta_d = 0 \text{ (no special device)}$	
<p><b>15 Logarithmic decrement</b></p>	$\delta = \delta_s + \delta_a + \delta_d = 0,05 + 0,026 + 0 = 0,076$	

Title	Appendix A Worked Example: Wind action on a multi-storey building	9 of 18
<p><b>16 Aerodynamic admittance functions</b></p> <p>Function <math>R_h</math>:</p> $R_h(\eta_h) = \frac{1}{\eta_h} - \frac{1}{2\eta_h^2} (1 - e^{-2\eta_h})$ $\eta_h = \frac{4,6h}{L(z_s)} f_L(z_s, n_{1,x}) = \frac{4,6 \times 35}{75,9} \times 2,87 = 6,09$ <p>Then, we obtain: <math>R_h(\eta_h) = 0,15</math></p> <p>Function <math>R_b</math>:</p> $R_b(\eta_b) = \frac{1}{\eta_b} - \frac{1}{2\eta_b^2} (1 - e^{-2\eta_b})$ $\eta_b = \frac{4,6b}{L(z_s)} f_L(z_s, n_{1,x}) = \frac{4,6 \times 120}{75,9} \times 2,87 = 20,9$ <p>Then, we obtain: <math>R_b(\eta_b) = 0,046</math></p> <p><b>17 Resonance response factor</b></p> $R^2 = \frac{\pi^2}{2\delta} S_L(z_s, n_{1,x}) \times R_h \times R_b$ $= \pi^2 \times 0,0664 \times 0,15 \times 0,046 / (2 \times 0,076)$ $= 0,0297$ <p><b>18 Peak factor</b></p> $v = n_{1,x} \sqrt{\frac{R^2}{B^2 + R^2}}$ $= 0,9 \times \sqrt{\frac{0,0297}{0,415 + 0,0297}} = 0,23 \text{ Hz } (> 0,08 \text{ Hz})$ $k_p = \sqrt{2 \times \ln(vT)} + \frac{0,6}{\sqrt{2 \times \ln(vT)}}$ $T = 600 \text{ s}$ <p>Then: <math>k_p = \sqrt{2 \times \ln(0,23 \times 600)} + \frac{0,6}{\sqrt{2 \times \ln(0,23 \times 600)}} = 3,33</math></p> <p><b>19 Structural coefficient for wind on the long side</b></p> $c_{s,c_d} = \frac{1 + 2 \times 3,33 \times 0,235 \times \sqrt{0,415 + 0,0297}}{1 + 7 \times 0,235} = 0,773$		<p>EN 1991-1-4 § B.2(6)</p> <p>EN 1991-1-4 § B.2(6)</p> <p>EN 1991-1-4 § B.2(6)</p> <p>EN 1991-1-4 § B.2(3)</p>

Title	Appendix A Worked Example: Wind action on a multi-storey building	10 of 18
<p><b>3.2.3. Wind on the gable</b></p> <p>Dimensions: <math>b = 10</math> m and <math>h = 35</math> m</p> <p>Several parameters remain the same as for the wind on the long side.</p> <p><b>1 Terrain category III:</b></p> $z_0 = 0,30 \text{ m}$ $z_{\min} = 5 \text{ m}$ <p><b>2 Reference height:</b></p> $z_s = 21 \text{ m } (> z_{\min} = 5 \text{ m})$ <p><b>3 Orography factor</b></p> <p>Since the slope of the upwind terrain is less than <math>3^\circ</math>, <math>c_o(z_s) = 1,0</math></p> <p><b>4 Roughness factor:</b></p> $c_r(z_s) = 0,915$ <p><b>5 Turbulence factor:</b></p> $k_1 = 1,0$ <p><b>6 Turbulence intensity:</b></p> $I_v(z_s) = 0,235$ <p><b>7 Turbulent length scale:</b></p> $L(z_s) = 75,9 \text{ m}$ <p><b>8 Background factor</b></p> $B^2 = \frac{1}{1 + 0,9 \left( \frac{b+h}{L(z_s)} \right)^{0,63}} = \frac{1}{1 + 0,9 \left( \frac{10+35}{75,9} \right)^{0,63}} = 0,607$ <p><b>9 Mean wind velocity at the reference height <math>z_s</math></b></p> $v_m(z_s) = 23,8 \text{ m/s}$ <p><b>10 Fundamental frequency <math>n_{1,x}</math></b></p> <p>It is estimated by the simplified formula: <math>n_{1,x} = \frac{\sqrt{d}}{0,1h}</math></p> $n_{1,x} = \frac{\sqrt{120}}{0,1 \times 35} = 3,1 \text{ Hz}$ <p><b>11 Non-dimensional power spectral density function</b></p> $S_L(z_s, n_{1,x}) = \frac{6,8 f_L(z_s, n_{1,x})}{(1 + 10,2 f_L(z_s, n_{1,x}))^{5/3}}$		
		EN 1991-1-4 § B.2(2)
		EN 1991-1-4 § B.1(2)

Title	Appendix A Worked Example: Wind action on a multi-storey building	11 of 18
<p> <math display="block">f_L(z_s, n_{1,x}) = \frac{n_{1,x} L(z_s)}{v_m(z_s)} = \frac{3,1 \times 75,9}{23,8} = 9,89</math> </p> <p> Then: <math display="block">S_L(z, n) = \frac{6,8 \times 9,89}{(1 + 10,2 \times 9,89)^{5/3}} = 0,0302</math> </p> <p><b>12 Logarithmic decrement of structural damping</b></p> <p><math>\delta_s = 0,05</math></p> <p><b>13 Logarithmic decrement of aerodynamic damping <math>\delta_a</math></b></p> <p><math>\rho = 1,25 \text{ kg/m}^3</math></p> <p><math>c_f = c_{f,0} = 0,9</math> for <math>d/b = 120/10 = 12</math></p> <p><math>m_e</math> is the equivalent mass per unit length: <math>m_e = 150 \text{ t/m}</math></p> <p>Therefore: <math display="block">\delta_a = \frac{0,9 \times 1,25 \times 10 \times 23,8}{2 \times 3,1 \times 150 \cdot 10^3} = 0,0003</math></p> <p><b>14 Logarithmic decrement of damping due to special devices</b></p> <p><math>\delta_d = 0</math> (no special device)</p> <p><b>15 Logarithmic decrement</b></p> <p><math>\delta = \delta_s + \delta_a + \delta_d = 0,05 + 0,0003 + 0 = 0,0503</math></p> <p><b>16 Aerodynamic admittance functions</b></p> <p>Function <math>R_h</math>:</p> <p><math display="block">\eta_h = \frac{4,6h}{L(z_s)} f_L(z_s, n_{1,x}) = \frac{4,6 \times 35}{75,9} \times 9,89 = 21,0</math></p> <p>Then, we obtain: <math>R_h(\eta_h) = 0,0465</math></p> <p>Function <math>R_b</math>:</p> <p><math display="block">\eta_b = \frac{4,6b}{L(z_s)} f_L(z_s, n_{1,x}) = \frac{4,6 \times 10}{75,9} \times 9,89 = 5,99</math></p> <p>Then, we obtain: <math>R_b(\eta_b) = 0,153</math></p> <p><b>17 Resonance response factor</b></p> <p><math display="block">R^2 = \pi^2 \times 0,0302 \times 0,0465 \times 0,153 / (2 \times 0,0503)</math></p> <p><math display="block">= 0,0211</math></p>		<p>EN 1991-1-4 § F.5(4)</p> <p>EN 1991-1-4 § F.5(1)</p> <p>EN 1991-1-4 § B.2(6)</p> <p>EN 1991-1-4 § B.2(6)</p>



Title	Appendix A Worked Example: Wind action on a multi-storey building	12 of 18
<p><b>18 Peak factor</b></p> $v = 3,1 \times \sqrt{\frac{0,0211}{0,607 + 0,0211}} = 0,568 \text{ Hz } (> 0,08 \text{ Hz})$ $k_p = \sqrt{2 \times \ln(0,568 \times 600)} + \frac{0,6}{\sqrt{2 \times \ln(0,568 \times 600)}} = 3,59$ <p><b>19 Structural coefficient for wind on the long side</b></p> $c_s c_d = \frac{1 + 2 \times 3,59 \times 0,235 \times \sqrt{0,607 + 0,0211}}{1 + 7 \times 0,235} = 0,884$ <p><b>3.3. Internal pressure coefficients</b></p> <p><b>3.3.1. Normal design situation</b></p> <p>It is assumed that the doors and windows are shut during severe storms, therefore:</p> $c_{pi} = +0,2$ <p>and <math>c_{pi} = -0,3</math></p> <p>If air leakage is uniform around the building, the reference height for the internal pressure is <math>z_i = z_e</math>. Therefore:</p> $q_p(z_i) = q_p(z_e)$ <p><b>3.3.2. Accidental design situation</b></p> <p>The most severe case happens when the opening is located in a zone with the highest value of the external pressure coefficient <math> c_{pe} </math>.</p> <ul style="list-style-type: none"> <li>• Windows accidentally open upwind, with wind on the long side. This face is dominant and the area of the openings is equal to 3 times the area of openings in the remaining faces. Therefore: <math display="block">c_{pi} = 0,9 \quad c_{pe} = 0,9 \times (+0,8) = 0,72</math> <p>The peak velocity pressure is maximum at the top of the building:</p> <math display="block">q_p(z_i) = q_p(z_e) = 1,09 \text{ kN/m}^2</math> </li> <li>• Windows accidentally open downwind, with wind on the long side. This face is dominant and the area of the openings is equal to 3 times the area of openings in the remaining faces. Therefore: <math display="block">c_{pi} = 0,9 \quad c_{pe} = 0,9 \times (-1,2) = -1,1</math> <math display="block">q_p(z_i) = q_p(z_e) = 1,09 \text{ kN/m}^2</math> </li> </ul>		<p>EN 1991-1-4 § B.2(3)</p> <p>EN 1991-1-4 § 7.2.9(6)</p> <p>EN 1991-1-4 § 7.2.9(7)</p> <p>EN 1991-1-4 § 7.2.9(3)</p> <p>EN 1991-1-4 § 7.2.9(5)</p>

- Windows accidentally open upwind, wind on the gable:  
 $c_{pi} = 0,9$   $c_{pe} = 0,9 \times (+0,7) = 0,6$
- Windows accidentally open downwind, wind on the gable:  
 $c_{pi} = 0,9$   $c_{pe} = 0,9 \times (-1,2) = -1,1$

### 3.4. Resulting pressure coefficients on parapets

The peak velocity pressure at the top of the building ( $z_e = 35$  m) is:

$$q_p(z_e) = 1,09 \text{ kN/m}^2$$

The solidity ratio is:  $\varphi = 1$

#### 3.4.1. Parapets on the long side – Wind on the long side

The parameters are:

$$\begin{aligned} \ell &= 120 \text{ m} && \text{Length of the parapet} \\ h_p &= 1,50 \text{ m} && \text{Height of the parapet} \\ \ell &> 4 h_p \end{aligned}$$

The different zones are in Figure A.4 with the pressure coefficients  $c_{p,net}$ .

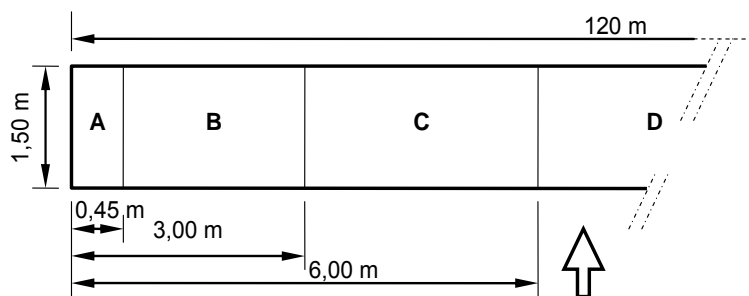

Zone A:  $c_{p,net} = 2,1$   
 Zone B:  $c_{p,net} = 1,8$   
 Zone C:  $c_{p,net} = 1,4$   
 Zone D:  $c_{p,net} = 1,2$

Figure A.4 Pressure coefficients  $c_{p,net}$  on the parapet – Long side

#### 3.4.2. Parapets on gable – Wind on gable

The parameters are:

$$\begin{aligned} \ell &= 10 \text{ m} && \text{Length of the parapet} \\ h_p &= 1,50 \text{ m} && \text{Height of the parapet} \\ \ell &> 4 h_p \end{aligned}$$

The different zones are in Figure A.5 with the pressure coefficients  $c_{p,net}$ .

EN 1991-1-4  
 Table 7.9  
 Figure 7.19

EN 1991-1-4  
 Table 7.9  
 Figure 7.19

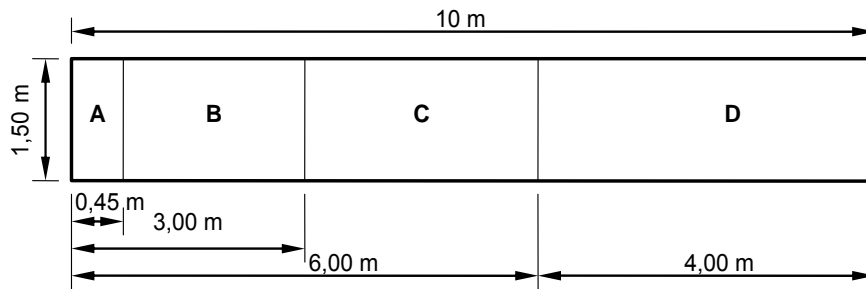

Zone A:  $c_{p,net} = 2,1$

Zone B:  $c_{p,net} = 1,8$

Zone C:  $c_{p,net} = 1,4$

Zone D:  $c_{p,net} = 1,2$

**Figure A.5 Pressure coefficients  $c_{p,net}$  on the parapet – Gable**

### 3.5. Friction forces

#### 3.5.1. Wind on the long side

Total area of the external surfaces parallel to the wind direction:

$$A_{pa} = 2 \times 35 \times 10 + 120 \times 10 = 1900 \text{ m}^2$$

Total area of the external surfaces perpendicular to the wind direction:

$$A_{pe} = 2 \times 35 \times 120 = 8400 \text{ m}^2$$

Since  $A_{pa} < 4 A_{pe}$ , the friction forces should not be taken into account.

EN 1991-1-4  
§ 5.2(4)

#### 3.5.2. Wind on the gable

Total area of the external surfaces parallel to the wind direction:

$$A_{pa} = 2 \times 35 \times 120 + 120 \times 10 = 9600 \text{ m}^2$$

Total area of the external surfaces perpendicular to the wind direction:

$$A_{pe} = 2 \times 35 \times 10 = 700 \text{ m}^2$$

Since  $A_{pa} > 4 A_{pe}$ , the friction forces should be taken into account.

EN 1991-1-4  
§ 5.2(4)

$$2 b = 20 \text{ m}$$

$$4 h = 140 \text{ m} > 2 b$$

The friction forces apply on the part of external surfaces parallel to the wind, located beyond a distance from the upwind edge equal to 20 m. The friction force  $F_{fr}$  acts in the wind direction:

EN 1991-1-4  
§ 5.2(3)

$$F_{fr} = c_{fr} q_p(z_e) A_{fr}$$

where:

$$c_{fr} = 0,01 \text{ for a smooth surface (steel)}$$

$q_p(z_e)$  is the peak velocity pressure at the height  $z_e$  as given in Table A.1.

$A_{fr}$  is the relevant area.

The results are summarized in Table A.2 for the different strips of the vertical walls and for the roof.

**Table A.2 Friction forces – Wind on the gable**

Strip	$z_e$	$A_{fr}$ m <sup>2</sup>	$q_p(z)$ kN/m <sup>2</sup>	$F_{fr}$ kN
0	10 m	2000	0,72	14,4
10 m	15 m	1000	0,84	8,4
15 m	20 m	1000	0,92	9,2
20 m	25 m	1000	1,00	10,0
25 m	35 m	1700	1,09	18,5
Parapets	35 m	600	1,09	6,5
Roof	35 m	1000	1,09	10,9

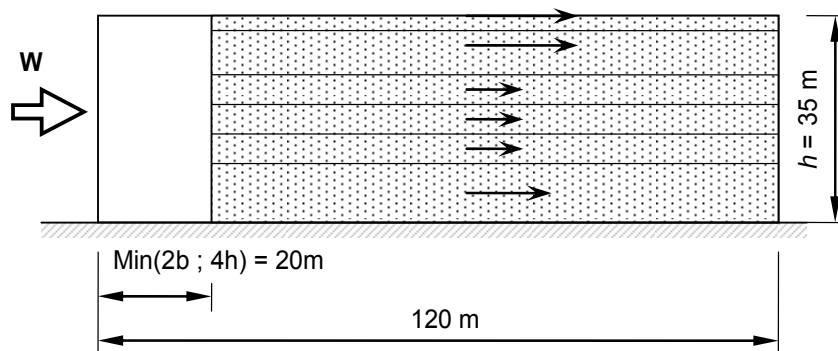

**Figure A.6 Friction forces – Wind on the gable**

### 3.6. Wind forces on surfaces

#### 3.6.1. General

There are three types of wind forces:

- Wind forces resulting from the summation of the external and internal pressure:

$$(F_{w,e} - F_{w,i}) / A_{ref} = c_s c_d q_p(z_e) c_{pe} - q_p(z_i) c_{pi} \quad (\text{in kN/m}^2)$$

They act normally to the surfaces. They are taken as positive values when they are directed towards the surface and as negative values when they are directed away from the surface.

- Friction forces (see Table A.2)

$$F_{fr} = c_{fr} q_p(z_e) A_{fr} \quad (\text{in kN})$$

They act on the external surfaces parallel to the wind direction.

- Wind forces on parapets

$$F_w = c_s c_d c_{p,net} q_p(z_e) A_{ref}$$

They act normally to the surfaces.

### 3.6.2. Wind on the long side

For wind on the long side, the structural factor is:  $c_s c_d = 0,773$

Regarding the normal design situation, the values of the resulting pressure are given in Table A.3 for the vertical walls and the roof:

$$(F_{we} - F_{wi})/A_{ref} = c_s c_d q_p(z_e) c_{pe} - q_p(z_i) c_{pi}$$

where:

$c_{pe}$  are the external pressure coefficients determined in § 3.1.1 for the vertical walls, and in § 3.1.2 for the roof.

$$q_p(z_e) = 1,09 \text{ kN/m}^2 \text{ as calculated in § 2.2}$$

$$q_p(z_i) = q_p(z_e) = 1,09 \text{ kN/m}^2 \text{ as stated in § 3.3.1}$$

Note that for wind on the long side, there are no friction forces for this building.

**Table A.3 Wind on the long side (kN/m<sup>2</sup>) – Vertical walls**

Zone	Vertical walls				Roof	
	A	D	E	F	G	H
$c_{pe}$	-1,2	+0,8	-0,6	-1,4	-0,9	-0,7
$c_{pi} = +0,2$	-1,23	+0,46	-0,72	-1,40	-0,98	-0,81
$c_{pi} = -0,3$	-0,68	+1,00	-0,18	-0,85	-0,43	-0,26

In Table A.4, the values of the resulting pressure are given for the parapet, using the formula:

$$F_w/A_{ref} = c_s c_d q_p(z_e) c_{p,net}$$

where:

$c_{p,net}$  are the pressure coefficient determined in § 3.4.1

$$q_p(z_e) = 1,09 \text{ kN/m}^2$$

**Table A.4 Wind on the long side (kN/m<sup>2</sup>) - Parapet**

Zone	A	B	C	D
$c_{p,net}$	2,1	1,8	1,4	1,2
$F_w / A_{ref} \text{ (kN/m}^2\text{)}$	1,77	1,52	1,18	1,01

Regarding the accidental design situation, the values of the resulting pressure are given in Table A.5 for the vertical walls and the roof, and for two situations:

- Opening in zone D ( $c_{pi} = +0,7$ )
- Opening in zone A ( $c_{pi} = -1,1$ )

**Table A.5 Wind on the long side (kNm<sup>2</sup>) – accidental design situation**

Zone	Vertical walls				Roof	
	A	D	E	F	G	H
$c_{pe}$	-1,2	+0,8	-0,6	-1,4	-0,9	-0,7
$c_{pi} = +0,7$	-1,77	-0,09	-1,27	-1,94	-1,52	-1,35
$c_{pi} = -1,1$	+0,19	+1,87	+0,69	+0,02	+0,44	+0,61

### 3.6.3. Wind on the gable

For wind on the gable, the structural factor is:  $c_s c_d = 0,884$

Regarding the normal design situation, the values of the resulting pressure are given in Table A.6 for the vertical walls and in Table A.7 for the roof:

$$(F_{we} - F_{wi})/A_{ref} = c_s c_d q_p(z_e) c_{pe} - q_p(z_i) c_{pi}$$

where:

$c_{pe}$  are the external pressure coefficients determined in § 3.1.1 for the vertical walls, and in § 3.1.2 for the roof

$q_p(z_e)$  is the peak velocity pressure in kN/m<sup>2</sup> as calculated in § 2.3

$q_p(z_i) = q_p(z_e)$  for each strip, as stated in § 3.3.1.

**Table A.6 Wind on the gable – Vertical walls**

Zone	A	B	C	D	E	
$c_{pe}$	-1,2	-0,8	-0,5	+0,7	-0,3	
$c_{pi} = +0,2$	$0 < z \leq 10$	-0,91	-0,65	-0,46	+0,30	-0,33
	$10 < z \leq 15$	-1,06	-0,76	-0,54	+0,35	-0,39
	$15 < z \leq 20$	-1,16	-0,83	-0,59	+0,39	-0,43
	$20 < z \leq 25$	-1,26	-0,91	-0,64	+0,42	-0,47
	$25 < z \leq 33,50$	-1,37	-0,99	-0,70	+0,46	-0,51
$c_{pi} = -0,3$	$0 < z \leq 10$	-0,55	-0,29	-0,10	+0,66	+0,03
	$10 < z \leq 15$	-0,64	-0,34	-0,12	+0,77	+0,03
	$15 < z \leq 20$	-0,70	-0,37	-0,13	+0,85	+0,03
	$20 < z \leq 25$	-0,76	-0,41	-0,14	+0,92	+0,03
	$25 < z \leq 33,50$	-0,83	-0,44	-0,15	+1,00	+0,04

**Table A.7 Wind on the gable - Roof**

Zone	F	G	H	I
$c_{pe}$	-1,4	-0,9	-0,7	-0,2
$c_{pi} = +0,2$	-1,57	-1,09	-0,89	-0,41
$c_{pi} = -0,3$	-1,02	-0,54	-0,35	+0,13

In Table A.8, the values of the resulting pressure are given for the parapet, using the formula:

$$F_w / A_{ref} = c_s c_d q_p(z_e) c_{p,net}$$

**Table A.8 Wind on the gable (kN/m<sup>2</sup>) - Parapet**

Zone	A	B	C	D
$F_w / A_{ref}$ (kN/m <sup>2</sup> )	2,02	1,73	1,35	1,16

### Accidental design situation

Regarding the accidental design situation, the values of the resulting pressure are given in Table A.9 for the vertical walls and in Table A.10 for the roof, and for two situations:

- Opening in zone D ( $c_{pi} = +0,6$ ) for  $25 \text{ m} \leq z \leq 33,50 \text{ m}$
- Opening in zone A ( $c_{pi} = -1,1$ ) for  $25 \text{ m} \leq z \leq 33,50 \text{ m}$

**Table A.9 Wind on the gable (kN/m<sup>2</sup>) – Vertical walls – Accidental design situation**

Zone	A	B	C	D	E
$c_{pi} = +0,6$	-1,81	-1,42	-1,13	+0,01	-0,94
$c_{pi} = -1,1$	+0,04	+0,44	+0,72	+1,87	+0,94

**Table A.10 Wind on the gable (kN/m<sup>2</sup>) – Roof – Accidental design situation**

Zone	F	G	H	I
$c_{pi} = +0,6$	-1,99	-1,51	-1,32	-0,84
$c_{pi} = -1,1$	-0,13	+0,34	+0,53	+1,01